



POWERTRONICS P.VT. LTD.



# SOLUÇÃO

EQUIPAMENTOS PARA REDES ELÉTRICAS

## PRODUCT CATALOG

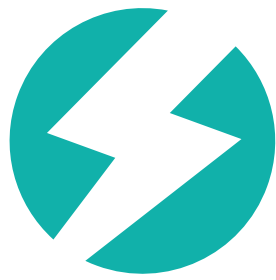

**SOLUÇÃO**  
EQUIPAMENTOS PARA REDE ELÉTRICA

Solução Equipamentos was established **20 years ago** to serve the electric sector, starting its activities as a distributor and manufacturer of tools and equipment for the construction and maintenance of electrical networks. We currently manufacture more than 95% of the products we sell, so we control all stages of the production process in order to achieve total quality.

Within our production process, we follow national (NBR) and international (IEC and ABNT) standards. We have our own laboratory, where we test our products under the strictest conditions as determined by the above mentioned standards, meeting specific requirements of the main electric power utilities in Brazil.

We count on professionals affiliated to the Brazilian Regional Council of Engineering and Architecture (CREA), who are qualified for customer services and to perform maintenance and testing services on tools and equipment.

Our main clients range from electric power utilities to their outsourced companies (contractors). Our products have been approved at the main public and private utilities in Brazil.

We have expanded our borders and, so far, we have exported our products to Argentina, Bolivia, Chile, Colombia, Ecuador, South Africa, the Philippines, Panama, Paraguay, Peru, Turkey, Uruguay, and Vietnam.

## **Mission**

Producing, assembling, and marketing products and services with assured quality, generating value to customers, employees, suppliers, and our society.

## **Vision**

To be attested as a reference in the manufacture of electrical network maintenance equipment, providing special products and services throughout the national and international territory.

## **Values**

Ethics and transparency in our relationship with customers and suppliers, through excellence in services, with personal appreciation and development.



# TELESCOPIC HOT STICKS – LIGHT-WEIGHT AND METRIC MODELS



# TELESCOPIC HOT STICKS – LIGHT-WEIGHT AND METRIC MODELS

The triangular-shaped Telescopic Hot Stick has been designed according to strict manufacturing and testing processes, which allow SOLUÇÃO to guarantee its proven quality by fully complying with ASTM F 1826-00 requirements.

All sections are made of epoxy-resin impregnated fiberglass. Its top section is highlighted by its fluorescent color and polyurethane foam filling. Such features guarantee the Telescopic Hot Stick's excellence in its mechanical performance and dielectric strength.

Due to its triangular profile and telescopic functionality, its anatomical shape allows its quick extension to the working position, unlike conventional Sectional Hot Sticks that require more time to put their sections together.

The telescopic hot stick is provided with one bronze universal end fitting, which remains firmly attached to the telescopic hot stick with high-adhesion glue, and stainless steel cotter pins. This system allows working safely with several operational heads for multiple tasks.

Applications: Opening Load Switches with Load Stopping Tools, installing Temporary Grounding Sets, operating Voltage Testers etc.

We do not recommend working under rainy conditions or opening switches under severe jamming circumstances caused by a high degree of oxidation.

The following models are available to meet the requirements of each user according to the severity of the task to which it has been submitted:

## LIGHTWEIGHT TELESCOPIC STICK

PART N°	QTY. OF SESSIONS	EXTENDED LENGTH (mm)	COLLAPSED LENGTH (mm)	BOTTOM SECTION (mm)	APPROX. WEIGHT (kg)
SEVTT-2M	2	2.585	1.420	33	1,31
SEVTT-3M	3	3.823	1.470	37	1,91
SEVTT-4M	4	5.103	1.520	41	2,51
SEVTT-5M	5	6.440	1.580	45	3,21
SEVTT-6M	6	7.790	1.620	49	3,92
SEVTT-7M	7	9.180	1.670	52	4,75
SEVTT-8M	8	10.607	1.730	56	5,75
SEVTT-9M	9	12.070	1.760	61	6,95

## TELESCOPIC HOT STICK FOR HEIGHT MEASUREMENT

PART N°	QTY. OF SESSIONS	EXTENDED LENGTH (mm)	COLLAPSED LENGTH (mm)	BOTTOM SECTION (mm)	APPROX. WEIGHT (kg)
SEVTT-2	2	2.585	1.420	33	1,31
SEVTT-3	3	3.823	1.470	37	1,91
SEVTT-4	4	5.103	1.520	41	2,51
SEVTT-5	5	6.440	1.580	45	3,21
SEVTT-6	6	7.790	1.620	49	3,92
SEVTT-7	7	9.180	1.670	52	4,75
SEVTT-8	8	10.607	1.730	56	5,75
SEVTT-9	9	12.070	1.760	61	6,95

# REINFORCED AND EXTRA REINFORCED TELESCOPIC HOT STICK

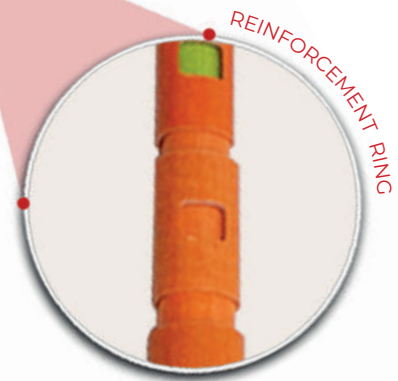

# REINFORCED AND EXTRA REINFORCED TELESCOPIC HOT STICK

The triangular-shaped Telescopic Hot Stick has been designed according to strict manufacturing and testing processes, which allow SOLUÇÃO to guarantee its proven quality by fully complying with ASTM F 1826-00 requirements.

All sections are made of epoxy-resin impregnated fiberglass. Its top section is highlighted by its fluorescent color and polyurethane foam filling. Such features guarantee the Telescopic Hot Stick's excellence in its mechanical performance and dielectric strength.

Due to its triangular profile and telescopic functionality, its anatomical shape allows its quick extension to the working position, unlike conventional Sectional Hot Sticks that require more time to put their sections together.

The telescopic hot stick is provided with one bronze universal end fitting, which remains firmly attached to the telescopic hot stick with high-adhesion glue, and stainless steel cotter pins. This system allows working safely with several operational heads for multiple tasks.

Applications: Opening Load Switches with Load Stopping Tools, installing Temporary Grounding Sets, operating Voltage Testers etc.

We do not recommend working under rainy conditions or opening switches under severe jamming circumstances caused by a high degree of oxidation.

PART N°	QTY. OF SESSIONS	EXTENDED LENGTH (mm)	COLLAPSED LENGTH (mm)	BOTTOM SECTION (mm)	APPROX. WEIGHT (kg)
SEVTT-3HD/4	2	2.740	1.520	41	1,80
SEVTT-3HD/5	3	4.075	1.590	45	2,50
SEVTT-3HD/6	4	5.427	1.620	49	3,20
SEVTT-3HD/7	5	6.815	1.660	52	4,00
SEVTT-3HD/8	6	8.243	1.750	56	5,00
SEVTT-3HD/9	7	9.708	1.780	61	6,20

PART N°	QTY. OF SESSIONS	EXTENDED LENGTH (mm)	COLLAPSED LENGTH (mm)	BOTTOM SECTION (mm)	APPROX. WEIGHT (kg)
SEVTT-2ER	2	2.740	1.385	33	1,35
SEVTT-3ER	3	4.075	1.500	37	1,85
SEVTT-4ER	4	5.427	1.620	41	2,55
SEVTT-5ER	5	6.815	1.760	45	3,25
SEVTT-6ER	6	8.243	1.880	49	4,00
SEVTT-7ER	7	9.708	2.000	52	4,95
SEVTT-8ER	8	10.000	2.110	56	6,00

# SECTIONAL HOT STICKS

SOLUÇÃO Sectional Hot Sticks are indispensable to ensure the required safety distance in maintenance interventions carried out on electrical systems, ranging from power generation ones to those in industry facilities. Applications are the most diverse, usually involving power utilities crews performing the following tasks:

- Opening/closing fuse switches and knife switches;
- Installation and removal of temporary grounding sets;
- Voltage detectors operation;
- Network cleaning;
- Operation of various tasks with the use of universal end-fittings;

The sectional hot sticks fiberglass pole is manufactured by the process of continuous filament of fiberglass, which involves fiberglass, resins, fillers, and additives necessary to provide the suitable mechanical and electrical strength for the purpose they have been designed to.

Additionally, the raw material of the metal components is brass or stainless steel.

The standard criteria by the main Brazilian electrical utilities and international standards are constantly taken into consideration, in order to meet our customers' quality expectation.

Main tests to which they are submitted:

- Tensile strength;
- Flexural strength;
- Torsional strength;
- Applied voltage test (100kV every 30cm);



## DIMENSIONS

PART N°	DESCRIPTION	OVERALL LENGTH (mm)	USABLE LENGTH (mm)
ESV-1	Ø32mm Hot Stick Upper Section	1450 (±5)	1250 (±5)
EIV-2	Ø38mm Hot Stick Middle Section	1450 (±5)	1450 (±5)
EPV-3	Ø38mm Hot Stick Lower Section	1450 (±5)	1250 (±5)

## SECTIONAL HOT STICKS

PART N°	QTY. SECTIONS	ESV-1	EIV-2	EPV-3	MAX. WORK VOLTAGE (kV)	ESTIMATED WEIGHT (kg)	OVERALL LENGTH (mm)
SEVM-1	1	1	--	--	20	1,2	1250
SEVM-2	2	1		1	150	2,3	2700
SEVM-3	3	1	1	1	300	3,7	3950
SEVM-4	4	1	2	1	400	4,85	5200

- Conditioning and carrying bags are manufactured in canvas (no. 10) and must be ordered separately.

# GRIP-ALL CLAMPSTICKS (SHOTGUN)

The Grip-all Clampsticks are fundamental for servicing, maintenance, and live line crews, when working by the Rubber Glove and Hot Stick Methods.

It is provided with a hinged and retractable hook mechanism operated by a 3-position sliding plastic hand grip, with a lockbar and a safety latch.

Load rated at 133daN.

Ø32mm GRIP-ALL CLAMPSTICKS MODELS					
PART N°	DIMENSIONS		INSULATED LENGTH (mm)	MAX. VOLTAGE (kV)	APPROXIMATE WEIGHT (kg)
	Ø (mm)	OVERALL LENGTH (mm)			
SE514-1302	32	1430	540	15	2,4
SE514-1303	32	2040	740	35	2,6
SE514-1304	32	2650	1300	138	3,1
SE514-1305	32	3260	1860	230	3,5
SE514-1306	32	3870	2420	345	3,9



# OPERATIONAL HEADS

SE3180



DISCONNECT HEAD FOR SWITCH OPERATION.

SE11995-2



BRONZE HEAD FOR SWITCH OPERATION.

SE14525-2



HEAD FOR SWITCH OPERATION AND HAND LINE INSTALLATION.

SE27594-2



TILTED ANGLE HEAD FOR SWITCH OPERATION.

SE16725-2



BRONZE "T" HEAD FOR SWITCH OPERATION.

SE19085-2



BRONZE HEAD WITH SHAFT FOR CUTOUT SWITCH OPERATION.

SE13680-2



CLAMP HEAD FOR TEMPORARY GROUNDING SET INSTALLATION.

SE18316-2



HEAD WITH SHAFT AND SPRING-ACTION MECHANISM FOR TEMPORARY GROUNDING SET INSTALLATION.

SE5566-30

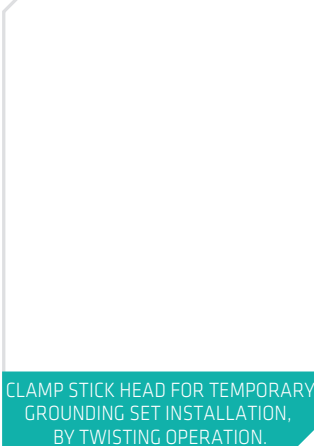

CLAMP STICK HEAD FOR TEMPORARY GROUNDING SET INSTALLATION, BY TWISTING OPERATION.

SE2978



UNIVERSAL ADAPTER FOR GRIP-ALL CLAMPSTICK.

SE25617-2



TOPPER HEAD FOR TELESCOPIC HOT STICK FOR HEIGHT MEASUREMENT.

SE27259-2



UNIVERSAL TREE-ROPE HOOK FOR MOVING CABLES/WIRES, PUSHING TREE LIMBS AND CLEARING TANGLED ROPES.

# RESCUE AND LIFTING GEAR AND ACCESSORIES

SE3131



60MM OPENING ANCHORAGE SNAP HOOK

SE3862



1kV INSULATED STRAIGHT ANCHORAGE HOOK

SE2469

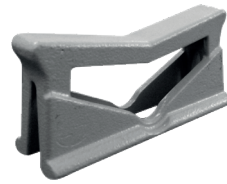

(SELF-BLOCKING) ABS BRAKE

SE2368



DOUBLE ACTION BLOCK. 225 daN WORK LOAD.

SE2365



DOUBLE ACTION BLOCK WITH 25M ROPE HOOK. 225daN WORK LOAD.

SE2352



STEEL SNAP HOOK FOR ROPE.

SE3341-2



ALUMINUM SNATCH BLOCK WITH FORGED STEEL HOOK AND SAFETY LOCK. RATED AT 567daN.

SE3341-3



ALUMINUM SNATCH BLOCK WITH STEEL MEAT HOOK. RATED AT 567daN.

SE10530-2



2,28M TWO-HOOK RESCUE STICK TO REACH AND SHIFT VICTIMS OUT OF ENERGIZED SYSTEMS. 220daN WORK LOAD.

SE4645



CURVED HOOK CABLE HANDLING STICK.

SE2950



HAND LINE HOOK MADE FROM STEEL. RATED AT 227daN.

SE4419



150MM OPENING ANCHORAGE HOOK, MADE FROM ALUMINUM. RATED AT 182daN.

SE3053 / SE3520

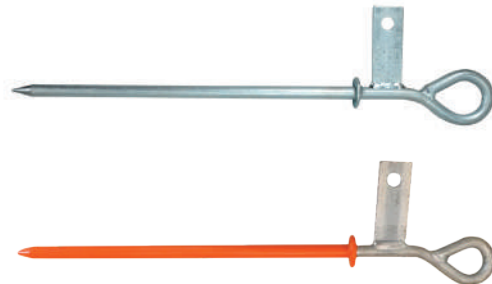

STEEL EYE-ROD / INSULATED STEEL EYE-ROD.

# RESCUE KIT FOR AERIAL LIFTS

The Rescue Kit for Insulated Aerial Lifts is provided with an anchor strap with rubber cover sewn onto the side that is in touch with the boom, to prevent damage. It is 400mm in length with a rupture load of 2500daN.

Dichromated ratchet with safety lock, work load of 900kg. Supplied with a protection cover made from the same material as that of the storage bag. A protection cover made from rubber and leather is sewn onto the side that is in touch with the aerial lift boom.

High-strength vinyl canvas bag, in orange color (Munsell 2.5 YR 6/14), with Velcro straps for easy access to the kit, from a distance.

Rope locking device made from high mechanical strength aeronautical aluminum. The device locks the rope in case of an unintentional release of the rope.

Violin-shaped rope block with pulley, equipped with rope untangling device. (Materials: Stainless steel, aluminum alloy and polymer material). Minimum breaking load of 900daN.

Double lock forged steel hook.

31m ( $\pm 1$  m) of  $\varnothing 11 \pm 1$ mm black rope. Polyester cover, double-braided polyamide core. Rupture load: 1800daN.

Shackle in stainless steel.

Max. Weight: 7kg.

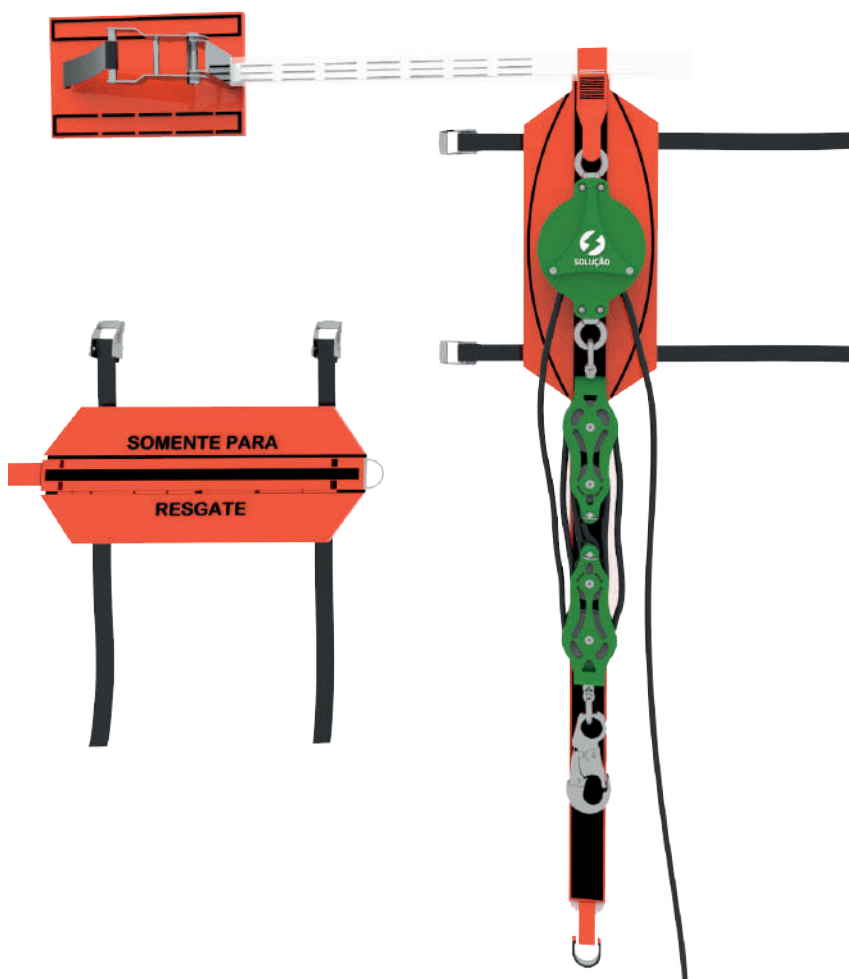

RESCUE KIT FOR  
AERIAL LIFTS

SE8590

# WORK PLATFORMS / ANCHORAGE ASSEMBLY



## NYLON SLINGS WITH STEEL RINGS

PART N°	DESCRIPTION
SE7720-2	500mm Nylon sling with steel rings for easy hot stick installation. 670daN load capacity.
SE7720-3	800mm Nylon sling with steel rings for easy hot stick installation. 670 daN load capacity.
SE7720-4	1200mm Nylon sling with steel rings for easy hot stick installation. 670 daN load capacity.
SE7720-5	1500mm Nylon sling with steel rings for easy hot stick installation. 670daN load capacity.

SE5400



SE6219



## PORTABLE STRAP-ON POLE PLATFORM IN POLYAMIDE FOR POLE CLIMBING

The Portable Strap-on Pole Platform is an easy-to-use tool for climbing double-T or round poles, manufactured from a fiberglass and nylon compound, making it highly resistant. Its attachment to poles is possible by means of a ratchet system, nylon and rubber straps that secure the platform firmly to the pole. Rated load: 160daN.

### AVAILABLE MODELS

**SE5400** - Portable Strap-on Platform for Round Poles

**SE6219** - Portable Strap-on Platform for double-T Poles

SE17534-2



Platform saddle with 800mm chain binder, manufactured in heat-treatment aluminum alloy and bronze. Its use is very simple and provides for the necessary foot support linemen need when working on poles. Rated work load: 360 daN. Approximate weight: 3.90kg.

PLATFORM SADDLE. RATED LOAD: 360daN

# WORK PLATFORMS/ ANCHORAGE

SE23675-2

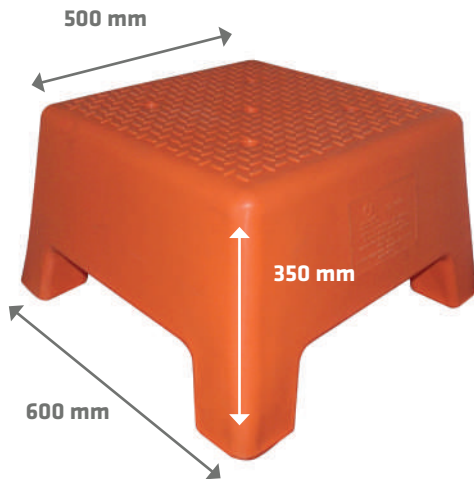

## TECHNICAL CHARACTERISTICS

RATED WORK VOLTAGE: **40 kV**

LOAD CAPACITY: **120 daN**

APPROXIMATE WEIGHT: **4 Kg**

**Application:** Used in electrical system interventions, during which electricians need to stand farther away from the ground potential, in addition to providing comfort as tasks are performed from a higher work position.

INSULATED STOOL, LOAD CAPACITY 120 daN

SE9092

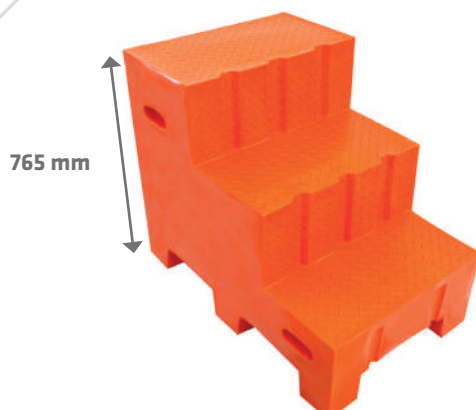

## TECHNICAL CHARACTERISTICS

WORKING HEIGHT: **765mm**

APPROXIMATE WEIGHT: **18 Kg**

STAND-ON STEPS

# LOCOMOTION AND SUPPORT SADDLES



SADDLE AND CLAMP

PART N°	DESCRIPTION	RATED CAPACITY	APPROXIMATE WEIGHT
		daN	kg
SE5851-4	Saddle with 38mm clamp	454	4,9
SE5851-6	Saddle with 64mm clamp	454	5,1



SADDLE, EXTENSION AND CLAMP

PART N°	DESCRIPTION	RATED CAPACITY	APPROXIMATE WEIGHT
		daN	kg
SE5851-27	Saddle with 38mm clamp and extension	363	5,40
SE5851-29	Saddle with 64mm clamp and extension	363	5,60



SADDLE AND SHACKLE

PART N°	DESCRIPTION	RATED CAPACITY	APPROXIMATE WEIGHT
		daN	kg
SE5851-21	Saddle with shackle	454	4,1



SADDLE, EXTENSION AND SHACKLE

PART N°	DESCRIPTION	RATED CAPACITY	APPROXIMATE WEIGHT
		daN	kg
SE5851-31	Saddle with shackle and extension	363	4,6

# LOCOMOTION AND SUPPORT SADDLES



POLE CLAMP ONLY

PART N°	DESCRIPTION	APPROXIMATE WEIGHT (Kg)
SE5852-2	38mm pole clamp only	0,8
SE5852-3	51mm pole clamp only	0,9
SE5852-4	64mm pole clamp only	1,3
SE5852-6	76mm pole clamp only	1,8



POLE CLAMP WITH RING

PART N°	POLE DIAM. (mm)	RATED LOAD (daN)	APPROXIMATE WEIGHT (Kg)
SE5854	38	560	1,1
SE5854-2	51	560	1,2
SE5854-3	64	560	1,3



PART N°	DESCRIPTION	APPROXIMATE WEIGHT (Kg)
SE513-1103	64/38mm double pole clamp	1,3
SE14661-3	64/32mm double pole clamp	1,2
SE14661-4	38/32mm double pole clamp	1,1

DOUBLE POLE CLAMP

SE2959



900 MM CHAIN TIGHTENER.  
RATED LOAD 1134 daN

SE511-1184



SADDLE EXTENSION

SE2957W



BRACKET WITH WHEEL TIGHTENER,  
FOR ROPES. RATED LOAD 454 daN

# UNIVERSAL TOOLS AND ACESSORIES

SE5566-33



BALL SOCKET ADJUSTER

SE5566-20



COTTER KEY

SE5566-34



HACK SAW

SE5566-95



UNIVERSAL ADAPTER

SE5566-05



COTTER KEY PULLER

SE5566-213



CLEVIS PIN INSTALLER

SE5566-23



SNAPOUT COTTER KEY REMOVER

SE5566-26



LOCATING PIN

SE5566-7



RATCHET WRENCH

SE5566-57



FLEXIBLE WRENCH HEAD FOR HEXAGONAL SOCKET

SE5566-48



CHUCK BLANK (TOOLS ADAPTER)

SE5566-3



PIN HOLDER

# UNIVERSAL TOOLS AND ACESSORIES

SE5566-98



BALL SOCKET ADJUSTER

SE514-1237



BALL SOCKET ADJUSTER

SE514-1286



PLASTIC INSULATOR TOOL  
(BALL SOCKET ADJUSTER)

SE2059-4



RATCHET WRENCH

SE5566-39



SCREW DRIVER

SE5566-29



COTTER KEY INSTALLER

SE514-1117



COTTER KEY RE-PLACER TOOL

SE5566-214



MULTI-ANGLE COTTER KEY HOLDER

SE514-1116



COTTER KEY TOOL

# DAYLIGHT WARNING SPHERES

The daylight warning spheres manufactured by Solução have been designed to identify electrical distribution and transmission networks, fully complying with the Brazilian NBR15237 standard.

They are manufactured from high density polyethylene with anti-ultraviolet additives and pigmented in orange Munsell 2.5YR 6/14 color notation.

Its main constructive characteristics are as follows:

- a) Resistant to impact and permanent deformation;
- b) High fatigue and bad weather strength;
- c) Color and brightness immutability;
- d)  $(600 \pm 10)$  mm external diameter;
- e) Water drainage holes, evenly distributed along its diameter, for perfect water drainage in any position;
- f) Anchoring system for attachment to aluminum or steel ground cables. Protection pads prevent abrasion and crushing;
- g) Smooth surface guaranteed;
- h) Rotation-proof. Under windy conditions (winds of up to 7 m/s) the sphere must never rotate;

Conventional installation models are available as listed below:



PART N°	Connection (mm)	Approx. Weight (kg)
ROT20909-2	6 to 8	5,60
ROT20909-3	8,1 to 9,5	5,60
ROT20909-4	9,51 to 10,5	5,60
ROT20909-5	10,51 to 11,5	5,60
ROT20909-6	11,51 to 12,5	5,60
ROT20909-7	12,51 to 13,5	5,60
ROT20909-8	13,51 to 14,5	5,60
ROT20909-9	14,51 to 15,5	5,60
ROT20909-10	15,51 to 16,5	5,60
ROT20909-11	16,51 to 17,5	5,60
ROT20909-12	17,51 to 18,5	5,60
ROT20909-13	18,51 to 19,5	5,60
ROT20909-14	19,51 to 20,5	5,60
ROT20909-15	20,51 to 21,5	5,60
ROT20909-16	21,51 to 22,5	5,60
ROT20909-17	22,51 to 23,5	5,60
ROT20909-18	23,51 to 24,5	5,60
ROT20909-19	24,51 to 25,5	5,60

# LOAD STOPPING TOOL 100% BRAZILIAN

*Brazil's first device designed to open energized switches,  
homologated by the main Brazilian Electrical Utilities.*

Portable Device for opening energized switches. Light-weight, practical and efficient in extinguishing the electrical arc when opening knife and fuse switches. Two models are available: one for 24.5kV switches and another for 34.5kV switches.

Nominal current: 600A or Maximum current: 900A.

Both models are supplied with an automatic operations marker and a universal fitting for conventional and telescopic Hot Stick, tested according to IEC 62271-103 international standard.

Both models are supplied in our original high strength polymer case, for conditioning and transport purposes.

24.5kV LOAD-STOPPING TOOL  
WITH AUTOMATIC  
OPERATIONS MARKER

SE2846



34.5kV LOAD-STOPPING TOOL  
WITH AUTOMATIC  
OPERATIONS MARKER

SE2847

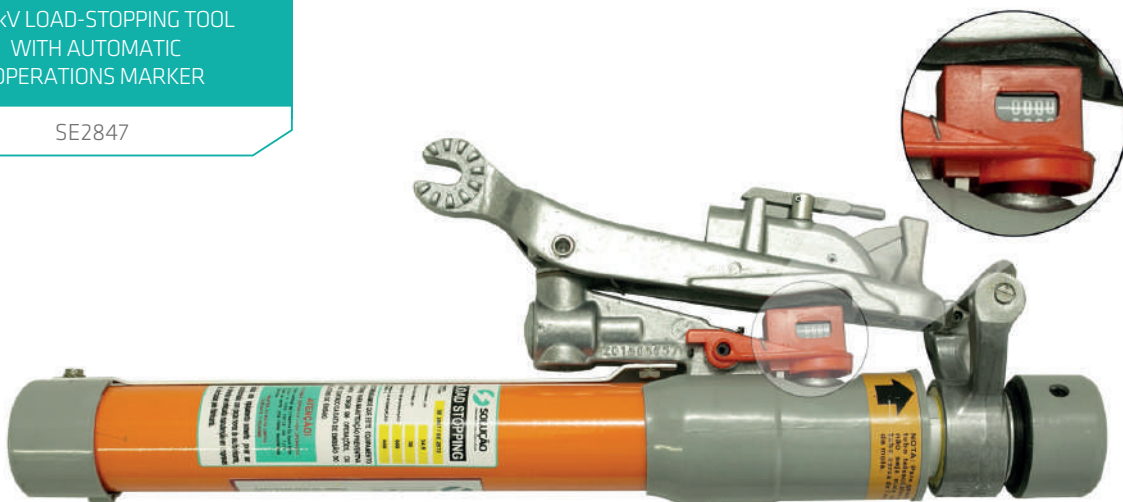

# TOOL SPIN CONNECT 1000 / 2000

**PATENTED PRODUCT**

These sets are intended for application / extraction of wedge-type connectors - blue, red and yellow series\*.

Shooting is accomplished by our unique ring system for easy connection. Tool Spin Connect devices are light-weight, offering safe and practical operation. Their exclusive safety system prevents unintentional shootings and requires the user to perform two voluntary movements before shooting (patent required). They also work with metallic shells.

TOOL SPIN CONNECT  
1000

SE2574



TOOL SPIN CONNECT  
2000

SE2237



**Note:**  
Items marked with (\*)  
belong to the Tool Spin  
Connect 2000 set

## SETS COMPOSITION

- 01 Shooting unit
- 01 Power unit
- 01 Small head
- 01 Big head\*
- 01 Steel Cleaning Brush
- 04 Tool Spin 1000 bullet holder
- 06 Tool Spin 2000 bullet holder

- 01 Lifting Platform - red connector
- 01 Extraction Platform - blue connector
- 01 Extraction Platform - red connector
- 01 Extraction Platform - yellow connector\*
- 01 Steel Cleaning Brush
- 01 Electrostatic paint metallic case

# IMPACT TOOLS



IMPACT TOOLS

MAR01

The Impact Tool has been designed for the installation of wedge-type connectors (blue and red models). They are actuated by a hammer and use plastic cartridges.

IMPACT TOOLS  
MAR02

The Impact Tool has been designed for the installation of wedge-type connectors (red, blue and yellow models). They are actuated by a hammer and use plastic cartridges.



# TEST AND DETECTION INSTRUMENTS



SE2562

DYNAMOMETER FOR INPUT ELECTRIC METER TEST  
RATED LOAD: 55 daN



SE4250

DYNAMOMETER HOOK



PROXIMITY VOLTAGE TESTER DTA-138

PART N°	VOLTAGE RANGE
DTA-138	1 kV to 138 kV
DTA-800	1 kV to 800 kV



PROXIMITY VOLTAGE TESTER DTA-35

PART N°	VOLTAGE RANGE
DTA-35	1 kV to 35 kV

# TEST AND DETECTION INSTRUMENTS



"MULTIUSO" PROXIMITY VOLTAGE TESTER

PART N°	VOLTAGE RANGE
DTM15	110V TO 15kV
DTM25	110V TO 25kV
DTM35	110V TO 35kV
DTM40	110V TO 40kV
DTM50	110V TO 50kV
DTM36	220V TO 36kV



HOT LINE "ZERO VOLTAGE" TESTER (CONTACT)

PART N°	VOLTAGE RANGE
DAT 5 - 40	05kV TO 40kV
DAT 12 - 36	12kV TO 36kV
DAT 10 - 40	10kV TO 40kV
DAT 36 - 60	36kV TO 60kV
DAT 20 - 80	20kV TO 80kV
DAT 60 - 180	60kV TO 180kV



DAT-A1-40



DAT-A1-40T

HOT LINE "ZERO VOLTAGE" TESTER FOR SHIELDED NETWORK OR BARE NETWORK (PROXIMITY)

PART N°	VOLTAGE RANGE
DAT-A1-40	01kV TO 40kV
DAT-A1-40T	01kV TO 40kV

# TEST AND DETECTION INSTRUMENTS (BY CONTACT)

## CONTACT VOLTAGE TESTERS

### LOW VOLTAGE



Contact voltage tester with on/off switch, voltage range: 50V to 1kV. **DTC-CH50-1000**

Stand-by contact voltage tester, voltage range: 70V to 1kV. **DTC-SB70-1000**

Stand-by contact voltage tester, voltage range: 100 to 1kV. **DTC-SB100-1000**

\*Partially meets IEC61243-1/03 standard requirements

### MEDIUM VOLTAGE



Stand-by contact voltage tester, voltage range: 2 to 8kV. **DTC-SB2-8**

Stand-by contact voltage tester, voltage range: 3,8 to 36kV. **DTC-SB3.8-36**

Stand-by contact voltage tester, voltage range: 5 to 15kV. **DTC-SB5-15**

Stand-by contact voltage tester, voltage range: 5 to 15kV. **DTC-SB5-15**

Stand-by contact voltage tester, voltage range: 10 to 40kV. **DTC-SB10-40**

Stand-by contact voltage tester, voltage range: 12 to 36kV. **DTC-SB12-36**

Stand-by contact voltage tester, voltage range: 20 to 80kV. **DTC-SB20-80**

### HIGH VOLTAGE



Stand-by contact voltage tester, voltage range: 60 to 180kV. **DTC-SB60-180**

Stand-by contact voltage tester, voltage range: 180 to 540kV. **DTC-SB180-540**

## CONTACT VOLTAGE TESTERS WITH ELECTRODE EXTENSION



CSU stand-by voltage tester, voltage range: 3,8 to 36kV. **DTC-CSU-SB3.8-36**

\*\*Meets IEC61243-1/03 standard requirements

# TEST AND DETECTION INSTRUMENTS



MINI HOT STICK TESTER  
TBM-127 AND TBM-220



HOT STICK TESTER  
TB-127 AND TB-220



## PHASE TESTER

The SE-TF Phase Tester has been designed for phase-phase and phase-ground voltage measurements on electrical transmission and distribution circuits. By means of a digital voltage meter, the tester monitors the angular phase difference between phases. It can also determine if the rotation sequence of the phases is positive or negative.

### AVAILABLE MODELS

**SE-TF16** - Voltage range 0kV to 16kV

**SE-TF100** - Voltage range 0kV to 100kV

**SE-TF16B\*** - Voltage range 0kV to 16kV

**SE-TF100B\*** - Voltage range 0kV to 100kV

*\* Supplied with one 1,7m universal pole  
(IMPORTANT: Accessories / pair of extensions are not required.)*



## MINI CONTACT VOLTAGE TESTER

Mini contact voltage tester, with On/Off switch. Voltage range: 50V to 600V.

Such testers are used by agents taking readings in consumers' units.

**MDTC/CH-50-600**

# TEMPORARY JUMPERS



15KV TEMPORARY JUMPER WITH DUCKBILL CLAMP

PART N°	CABLE SIZE (AWG)	CABLE CONNECTION RANGE		TOTAL LENGTH (M)	RATED CURRENT (A)	APPROX. WEIGHT (KG)
		MIN.	MAX.			
SE28554-2	2	Ø 4MM	Ø 29MM	3,7	200	4,8
SE28554-6				4,6		5,5
SE28554-3	1/0	Ø 4MM	Ø 29MM	3,7	260	7,10
SE28554-7				4,6		8,40
SE28554-4	2/0	Ø 4MM	Ø 29MM	3,7	300	8,3
SE28554-8				4,6		9,8
SE28554-5	4/0	Ø 4MM	Ø 29MM	3,7	400	10,7
SE28554-9				4,6		12,8



15KV TEMPORARY JUMPER WITH BY-PASS INSULATED CLAMP

PART N°	CABLE SIZE (AWG)	CABLE CONNECTION RANGE		TOTAL LENGTH (M)	RATED CURRENT (A)	APPROX. WEIGHT (KG)
		MIN.	MAX.			
SE712-1282	2	Ø 4MM	Ø 29MM	3,7	200	5,2
SE712-1283	1/0	Ø 4MM	Ø 29MM	3,7	260	6,7
SE712-1284	2/0	Ø 4MM	Ø 29MM	3,7	300	7,8
SE712-1285	4/0	Ø 4MM	Ø 29MM	3,7	400	10,2



TEMPORARY JUMPER FOR TRANSFORMER BUSHING WITH PROTECTION DEVICE - SE28559-2

PART N°	QTD.	DESCRIPTION
SE35	3,5m	15kV rated 35mm <sup>2</sup> jumper cable
SE22280-3	1pc	Clamp for Transformer bushing, with insulating handle
SE4733-2	1pc	Duckbill ground clamp with eye-screw
SE2711-8	1pc	Insulating Hanger
SE16895-2	1pc	Protection device for temporary jumper sets



TEMPORARY JUMPER FOR TRANSFORMER BUSHING WITH TEMPORARY FUSE- SWITCH - SE28550-2

REFERÊNCIA	QTD.	DESCRIÇÃO
SE35	3,5m	15kV rated 35mm <sup>2</sup> jumper cable
SE22280-3	1pc	Clamp for Transformer bushing, with insulating handle
SE4733-2	1pc	Duckbill ground clamp with eye-screw
SE7111-2906	1pc	100A rated Temporary fuse switch

# TEMPORARY JUMPERS AND INSULATING SUPPORTS

SE23510-2



The TEMPORARY BY-PASS FOR FUSE SWITCHES has been designed to offer an alternative path for the passage of the electric current going through fuse switches. It makes it possible for fuse links to be replaced, without disconnecting the circuit.

One model fits all, suitable for 15kV, 25kV and 34.5kV fuse switches, up to 100A.

Connection range: min.: 293mm - max.: 434mm.

TEMPORARY BY-PASS FOR FUSE SWITCHES, THREADED MECHANISM WITH EYE-LINK, RATED VOLTAGE: 25KV

SE511-1628



The TEMPORARY CONDUCTOR SUPPORT has been designed to support live distribution conductors. Its C-type clamp provides for attachment to 82x102mm to 152x152mm crossarms.

The C-shaped clamp and the U-shaped wireholder are cast in heat-treated aluminum alloy. They are attached to the polyurethane-foam filled fiberglass pole section which ensures the required insulating clearance between the cable and the pole structure. Installation can be done with a Grip-all Clampstick (Hot Stick Method).

Rated work load: 68 daN.

CROSSARM-MOUNT TEMPORARY CONDUCTOR SUPPORT

SE7487



The SWITCH JUMPER SUPPORT features one polyurethane-foam filled fiberglass pole section, with a C-type vice clamp for attachment to crossarms of up to 112mm high and a grounding clamp (SE4514) attached to the top end of the pole, to secure the jumper.

Rated work load: 68 daN.

CROSSARM-MOUNT SWITCH JUMPER SUPPORT

# TEMPORARY JUMPERS AND INSULATING SUPPORTS

SE22280-2



TRANSFORMER BUSHING CLAMP WITH EYE-SCREW

SE22280-3



TRANSFORMER BUSHING CLAMP WITH INSULATED HANDLE AND RUBBER STORM SKIRT

SE22280-4



TRANSFORMER BUSHING CLAMP WITH TIGHTENING T-SCREW

SE4733-2



BY-PASS CLAMP, WITH EYE-SCREW

SE712-1140



INSULATED BY-PASS CLAMP, RATED UP TO 34.5kV

SE2711-8



INSULATING HANGER FOR TEMPORARY JUMPER UP TO 34.5kV

SE16895-2



PROTECTION DEVICE FOR TEMPORARY JUMPER, RATED CURRENT: 100A

SE711-2906



TEMPORARY FUSE SWITCH FOR VOLTAGES UP TO 27kV (100A)

SE8400 / SE3630 / SE3631



TEMPORARY BY-PASS FOR 15, 25 AND 34.5kV FUSE SWITCHES

# COPPER FERRULES AND JUMPER CABLES



## TEMPORARY JUMPERS FERRULES, THREADED, UNSHROUDED

PART N°	DESCRIPTION	CABLE GAUGE (NOMINAL SIZE)	APPLICATION
SE711-3609	COPPER FERRULE FOR JUMPER CABLES, WITH 5/8" THREADS, FOR CONNECTION TO INSULATED CLAMPS OR CLAMPS WITH ADAPTORS.	2AWG (35MM <sup>2</sup> )	TEMPORARY JUMPERS
SE711-3600		1/0 (50MM <sup>2</sup> )	
SE711-3711		2/0 (70MM <sup>2</sup> )	
SE711-3712		4/0 (95MM <sup>2</sup> )	



## TEMPORARY JUMPERS FERRULES, THREADED, SHROUDED

PART N°	DESCRIPTION	CABLE GAUGE (NOMINAL SIZE)	APPLICATION
SE12930-2	COPPER FERRULE FOR JUMPER CABLES, <b>SHROUDED</b> , WITH 5/8" THREADS, FOR CONNECTION TO INSULATED CLAMPS OR CLAMPS WITH ADAPTORS.	2AWG (35MM <sup>2</sup> )	TEMPORARY JUMPERS
SE12930-3		1/0 (50MM <sup>2</sup> )	
SE12930-4		2/0 (70MM <sup>2</sup> )	
SE12930-5		4/0 (95MM <sup>2</sup> )	

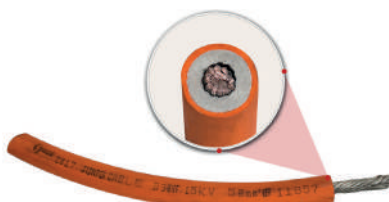

## EPR-PROTECTED JUMPERS CABLES, RATED AT 15KV

PART N°	DESCRIPTION	CROSS-SECTION (MM <sup>2</sup> )	CABLE SIZE (AWG)	NOMINAL COPPER CONDUCTOR DIAM. (MM)	MAX. CURRENT RATING(A)	APPROX. WEIGHT (KG per meter)
SE4511	INSULATED JUMPER CABLES, MADE FROM MONOPOLAR COPPER. ETHYLENE-PROPYLENE INSULATING MATERIAL (EPR RUBBER) SHEATHING. FOR WORKS ON DISTRIBUTION NETWORKS UP TO 15KV.	35	2	8	200	0,77 KG
SE4555		50	1/0	10	260	1,40 KG
SE4556		70	2/0	12	300	1,70 KG
SE4557		95	4/0	15	400	2,35 KG

# TEMPORARY JUMPERS

## PORTABLE TEMPORARY SWITCH SET

Temporary Portable Switch Set used on temporary switch installation tasks, aiming at minimizing the impacts of programmed and/or accidental shutdowns on electrical power distribution networks, consisting of:



PART N°	QTY.	DESCRIPTION
SE4733-2	06 pcs	Ø 4mm / Ø 30mm Ground Clamp, made from aluminum alloy. Tightening Screw and ferrules are made from bronze/ aluminum.
SE120	10 m	Extra-flexible Electrolytic copper cable with 750V clear-vision PVC sheathing. Cross-section: 120mm <sup>2</sup> - 2off 2m-long cables and 2off 3m-long cables.
7040	06 pcs	Compression ferrules for 120mm <sup>2</sup> cable - with 2 holes.
SE120	03 pcs	15kV Polymeric Cutout Switch. Rated current: 630A.
7288	1 pc	Pole fastening sleeve.
7286	3 pcs	Cross-arm supporting sleeve.
7285	4 pcs	Eye-ring for attachment of the sleeve to the crossarm.
7275	1 pc	1.500 x 76 x 76 x 2mm Aluminum cross-arm.
7281	1 pc	Pole-mount wheel-tightener and chain assembly.
7313	2 pc	600 x 200 x 350mm Bag for Temporary Portable Switch Set
7314	1 pc	600 x 320 x 350mm Bag for Temporary Portable Switch Set

KNIFE-SWITCH RATED CAPACITY: 630A  
GROUND CLAMP RATED CAPACITY: 400A

# INSULATING PROTECTIVE COVER-UP



ROUND COVER-UPS RATED VOLTAGE 26.4kV (PHASE/PHASE)

PART N°	DESCRIPTION	DIMENSIONS
ROT22287-2	ROUND COVER-UP (NO RIBS). RATED VOLTAGE 26.4KV (PHASE/PHASE)	Ø 100MM X 300MM
ROT22287-3	ROUND COVER-UP (NO RIBS). RATED VOLTAGE 26.4KV (PHASE/PHASE)	Ø 100MM X 600MM
ROT22287-4	ROUND COVER-UP (NO RIBS). RATED VOLTAGE 26.4kV (PHASE/PHASE)	Ø 100MM X 900MM
ROT22287-5	ROUND COVER-UP (NO RIBS). RATED VOLTAGE 26.4kV (PHASE/PHASE)	Ø 100MM X 1200MM
ROT15598-2	ROUND COVER-UP (NO RIBS). RATED VOLTAGE 26.4kV (PHASE/PHASE)	Ø 150MM X 300MM
ROT15598-3	ROUND COVER-UP (NO RIBS). RATED VOLTAGE 26.4kV (PHASE/PHASE).	Ø 150MM X 600MM
ROT15598-4	ROUND COVER-UP (NO RIBS). RATED VOLTAGE 26.4kV (PHASE/PHASE).	Ø 150MM X 900MM
ROT15598-5	ROUND COVER-UP (NO RIBS). RATED VOLTAGE 26.4kV (PHASE/PHASE).	Ø 150MM X 1200MM

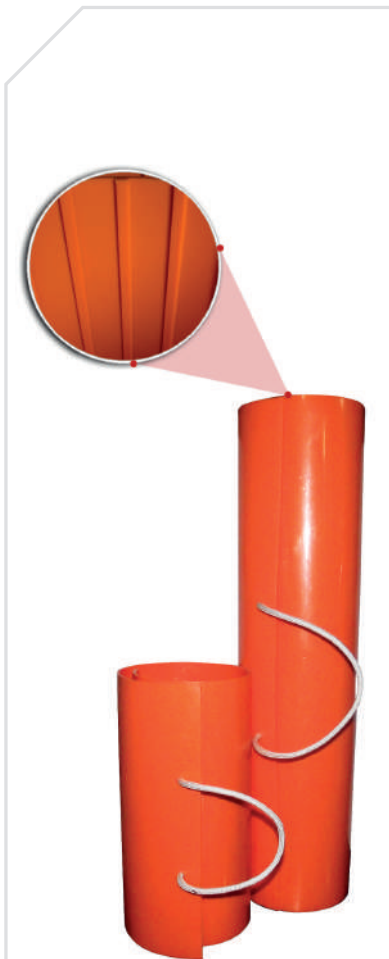

POLE COVER-UPS (RIBBED). RATED VOLTAGE 36.6kV (PHASE/PHASE)

PART N°	DESCRIPTION	DIMENSIONS
ROT517-1659	POLE COVER-UP (RIBBED) Ø 150MM X 300MM. RATED VOLTAGE 36.6kV.	Ø 150MM X 300MM
ROT711-1650	POLE COVER-UP (RIBBED) Ø 150MM X 600MM. RATED VOLTAGE 36.6kV (PHASE/PHASE).	Ø 150MM X 600MM
ROT517-1660	POLE COVER-UP (RIBBED) Ø 150MM X 1200MM. RATED VOLTAGE 36.6kV (PHASE/PHASE).	Ø 150MM X 1200MM
ROT5141662	POLE COVER-UP (RIBBED) Ø 150MM X 1800MM. RATED VOLTAGE 36.6kV (PHASE/PHASE).	Ø 150MM X 1800MM
ROT5048-2	POLE COVER-UP (RIBBED) Ø 230MM X 300MM. RATED VOLTAGE 36.6kV (PHASE/PHASE).	Ø 230MM X 300MM
ROT5048-3	POLE COVER-UP (RIBBED) Ø 230MM X 600MM. RATED VOLTAGE 36.6kV (PHASE/PHASE).	Ø 230MM X 600MM
ROT5048-4	POLE COVER-UP (RIBBED) Ø 230MM X 900MM. RATED VOLTAGE 36.6kV (PHASE/PHASE).	Ø 230MM X 900MM
ROT5048-5	POLE COVER-UP (RIBBED) Ø 230MM X 1200MM. RATED VOLTAGE 36.6kV (PHASE/PHASE).	Ø 230MM X 1200MM
ROT5048-7	POLE COVER-UP (RIBBED) Ø 230MM X 1800 MM. RATED VOLTAGE 36.6kV (PHASE/PHASE).	Ø 230MM X 1800MM
ROT517-1139	POLE COVER-UP (RIBBED) Ø 300MM X 300MM. RATED VOLTAGE 36.6kV (PHASE/PHASE).	Ø 300MM X 300MM
ROT517-1130	POLE COVER-UP (RIBBED) Ø 300MM X 600MM. RATED VOLTAGE 36.6kV (PHASE/PHASE).	Ø 300MM X 600MM
ROT517-1141	POLE COVER-UP (RIBBED) Ø 300MM X 1200MM. RATED VOLTAGE 36.6kV (PHASE/PHASE).	Ø 300MM X 1200MM
ROT517-1111	POLE COVER-UP (RIBBED) Ø 300MM X 1800MM. RATED VOLTAGE 36.6kV (PHASE/PHASE).	Ø 300MM X 1800MM

# INSULATING PROTECTIVE COVER-UP

ROT14446-2



RIGID PROTECTIVE CONDUCTOR COVER-UP.  
RATED VOLTAGE 26.4kV (PHASE/PHASE). WITHOUT CLAMP

ROT19946-2



RIGID PROTECTIVE CONDUCTOR COVER-UP.  
RATED VOLTAGE 36.6kV (PHASE/PHASE). WITHOUT CLAMP

ROT14444-2



RIGID PROTECTIVE COVER-UP FOR SECONDARY CONDUCTORS.  
RATED VOLTAGE 14,6kV (PHASE/PHASE).

ROT22258-2



RIGID PROTECTIVE COVER-UP FOR COMPACT DISTRIBUTION NETWORKS.  
RATED VOLTAGE 36,6kV (PHASE/PHASE).

ROT517-1292



RIGID PROTECTIVE COVER-UP WITH GRIP-ALL ADAPTER FOR HOT STICK  
INSTALLATION ON CONDUCTORS UP TO 25MM. RATED  
VOLTAGE 26.4kV (PHASE/PHASE).

ROT517-1295



RIGID PROTECTIVE COVER-UP FOR INSTALLATION ON CONDUCTORS  
UP TO 25MM. RATED VOLTAGE 26.4kV (PHASE/PHASE).

ROT5058



PIN INSULATOR COVER-UP. RATED VOLTAGE 26.4kV (PHASE/PHASE).

ROT22162-2



PIN INSULATOR COVER-UP WITH GRIP-ALL ADAPTER.  
RATED VOLTAGE 26.4kV (PHASE/PHASE).

ROT517-1668L



419MM PIN INSULATOR COVER-UP.  
RATED VOLTAGE 36.6kV (PHASE/PHASE).

ROT517-1293L



229MM PIN INSULATOR COVER-UP.  
RATED VOLTAGE 26.4kV (PHASE/PHASE).

# INSULATING PROTECTIVE COVER-UP

ROT22511-2



PROTECTIVE COVER-UP FOR DISC INSULATOR UP TO Ø160MM (DEADEND/ POLYMERIC), RATED VOLTAGE 26.4KV (PHASE/PHASE).

ROT5044



PROTECTIVE COVER-UP FOR CROSSARMS WITH PIN INSULATORS, RATED VOLTAGE 36.6KV (PHASE/PHASE)

ROT22284-2



PROTECTIVE COVER-UP FOR CROSSARMS WITH POST INSULATORS, RATED VOLTAGE 36.6KV (PHASE/PHASE)

ROT22284-3



PROTECTIVE COVER-UP FOR SHORT CROSSARMS WITH POST INSULATORS, RATED VOLTAGE 36.6KV (PHASE/PHASE)

ROT24456-2

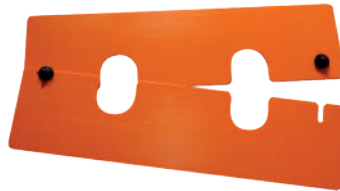

PROTECTIVE COVER-UP FOR KNIFE-SWITCH CARCASS (365X880MM), RATED VOLTAGE 26.4KV (PHASE/PHASE)

ROT22161-2



PROTECTIVE COVER-UP FOR LOSANGE CONDUCTOR SPACERS ON COMPACT DISTRIBUTION NETWORKS, RATED VOLTAGE 26.4KV (PHASE/PHASE)

ROT21876-2



PROTECTIVE COVER-UP FOR KNIFE-SWITCH CARCASS, RATED VOLTAGE 36.6KV (PHASE/ PHASE)

ROT22281-2



PROTECTIVE COVER-UP FOR C-SUPPORT ON COMPACT DISTRIBUTION NETWORKS, RATED VOLTAGE 26.4KV (PHASE/ PHASE)

ROT19672-2



PROTECTIVE COVER-UP FOR KNIFE-SWITCH, RATED VOLTAGE 26.4KV (PHASE/ PHASE)

ROT517-1110



PROTECTIVE COVER-UP FOR FUSE-SWITCH, RATED VOLTAGE 26.4KV (PHASE/ PHASE)

ROT22158-2



PROTECTIVE COVER-UP FOR HORIZONTAL SUPPORT ON COMPACT DISTRIBUTION NETWORKS, RATED VOLTAGE 26.4KV (PHASE/ PHASE)

# INSULATING PROTECTIVE COVER-UP

ROT22733-2



750MM STRAIGHT PROTECTIVE COVER-UP FOR BUSBARS, RATED VOLTAGE 26.4KV.

SE517-1658



ROPE LOCK ASSEMBLY FOR ROUND/POLE PROTECTIVE COVER-UP.

SE4577



LOCKING PIN MADE FROM NYLON FOR POLE TOP PROTECTIVE COVER-UP.

ROT5330 /ROT5329



Ø230MM X 270MM AND Ø275MM X 270MM POLE TOP PROTECTIVE COVER-UP.

SE22734-2



INSTALLATION FITTING FOR STRAIGHT PROTECTIVE COVER-UP FOR BUSBARS

SE27997-2



WITH TIP PROTECTION

SE15528-2



WITHOUT TIP PROTECTION

210MM LONG COVER-UP PEGS

# COMPRESSION TOOLS

Tools to crimp sleeves, connectors, and ferrules. They use interchangeable dies.

## HYDRAULICAL CRIMPER SE410

**Compression force:** 12 t

**Head opening:** 25 mm

**Opening for conductors:** from 6 to 400 mm<sup>2</sup>

**Weight:** 5,4kg (without case and die)



Tools can be supplied separately or with a suitable conditioning case.

## MECHANICAL CRIMPER SE6-8

**Compression force:** 4T

**Opening for sleeves and conductors:** from 10 to 4/0 AWG

**Fixed dies:** D3 and 0

**Weight:** 3,15kg (without case and die)



## DIES FOR MECHANICAL CRIMPER



Used to crimp connectors and sleeves to electrical cables.

They are supplied in different gauges for AAC, ACSR and Cu cables.

## M TYPE DIES FOR HYDRAULICAL CRIMPER SE 440



Dies are accessories used as a mold to crimp sleeves and connectors of wires and electrical cables.

They are supplied in pairs and according to indexes as defined by the customer, depending on the type of connector to be crimped.

Round or hexagonal shapes are available.

# TOOLS FOR WIRE CUTTING AND STRIPPING

SE28955-2 (100 mm)  
SE28955-3 (200 mm)



CUTTER FITTING HEAD  
FOR CABLES UP TO 35 MM<sup>2</sup>.

SE9500



DEVICE FOR CUTTING  
CABLES UP TO 16MM<sup>2</sup>.

SE2733



RATCHETING CONDUCTOR  
CUTTER (CUFF TYPE) -  
CUTTING CAPACITY Ø32MM  
(240 MM<sup>2</sup>).

SE3137 - 32 mm X 500 mm  
SE3516 - 32 mm X 2000 mm  
SE5683 - 32 mm X 1250 mm



TREE TRIMMER.

SE5374



CABLE STRIPPER WITH 1KV INSULATED HANDLES.  
SPACER CABLE STRIPPING CAPACITY FROM 35 MM<sup>2</sup> TO 300MM<sup>2</sup>.

SE5072



CABLE STRIPPER WITH 1KV INSULATED HANDLES.  
SPACER CABLE STRIPPING CAPACITY FROM 70 MM<sup>2</sup> TO 300MM<sup>2</sup>.

# TOOLS FOR WIRE CUTTING AND STRIPPING.

SE2618

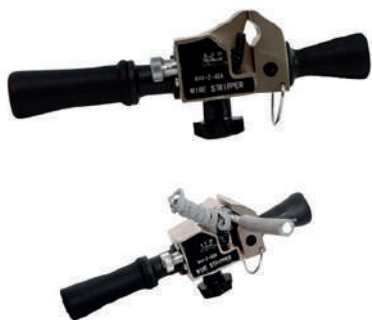

CABLE STRIPPER FOR REMOVAL OF CONDUCTORS XLPE TYPE INSULATION UP TO 10MM.  
CAPACITY: MIN.: Ø14MM - MAX. Ø40MM.

SE13929-2



CONDUCTOR CUTTER WITH ARTICULATED INSULATED HANDLES FOR 1/A ACSR GAUGES (Ø10.11MM)

SE5566-38-TR



PRUNNING SAW WITH UNIVERSAL FITTING AND 290MM CUTTING BLADE

SE8593



PRUNNING SAW WITH UNIVERSAL FITTING, HOOK AND 310MM TRIPLE CHIP CUTTING BLADE.

# BLOCKS FOR CABLE PULLING

SE3231



PULLEY FOR PULLING MESSANGER CABLES IN ANGLES

SE3313

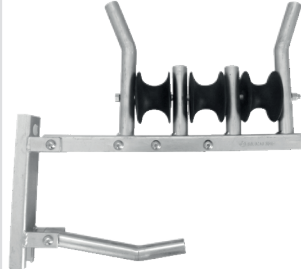

PULLEYS FOR REMOVING CONDUCTORS (TRIPLE)

SE3232



PULLEYS FOR PULLING PHASE CONDUCTORS

SE3233



PULLEY FOR PULLING PHASE CONDUCTORS IN ANGLES

SE3183



CROSSARM-MOUNT PULLEY BLOCK FOR PULLING CABLES

SE4654



PULLEY FOR PULLING MULTIPLEX CABLES ON LOW AND MEDIUM VOLTAGE NETWORKS

SE4707



SINGLE PULLEY FOR PULLING OPGW CABLES

SE4708



MULTIPLE PULLEYS FOR PULLING OPGW CABLES

SE3886



NEOPRENE SHEAVE

SE3885



POLISHED SHEAVE

SE3876



RUBBER SHEAVE

PULLEYS FOR PULLING MULTIPLEX CABLES

SE5838



PULLEY FOR ATTACHMENT TO THE SECONDARY FRAME STIRRUP

# TEMPORARY GROUNDING EQUIPMENT FOR DISTRIBUTION NETWORKS - SECONDARY, LOW VOLTAGE (LV) SYSTEMS

**TEMPORARY GROUNDING EQUIPMENT FOR SECONDARY SYSTEMS**

SE28540-2

INSULATING POLE  
NON-SLIPPING HANDLE

MAX. Isc: 8KA / 30 CYCLES

**TEMPORARY GROUNDING EQUIPMENT FOR SECONDARY SYSTEMS**

SE28540-3

INSULATING POLE  
NON-SLIPPING HANDLE

MAX. Isc: 8KA / 30 CYCLES

SE15625-3

SE15625-2

**TEMPORARY GROUNDING EQUIPMENT FOR MULTIPLEXED OR CONVENTIONAL NETWORKS**

SE24154-2

PRESSURE-TYPE GROUNDING CLAMP WITH PROTECTIVE HANDLES

500mm

500mm

500mm

MAX. Isc: 10KA / 30 CYCLES

# TEMPORARY GROUNDING EQUIPMENT FOR PRIMARY SYSTEMS ON HIGH VOLTAGE (HV) DISTRIBUTION NETWORKS, CUBICLES AND SUBSTATIONS

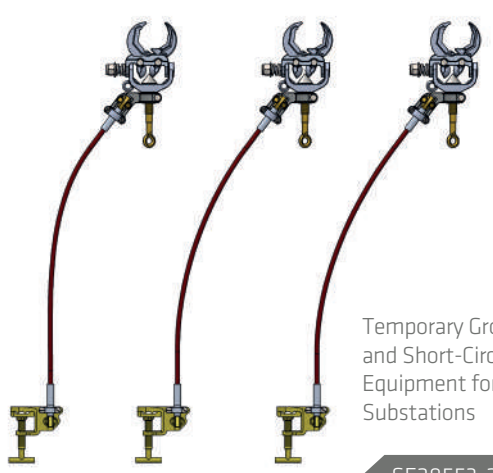

Temporary Grounding and Short-Circuiting Equipment for Substations

SE28553-2

MAX. Isc: 30 kA / 30 CYCLES

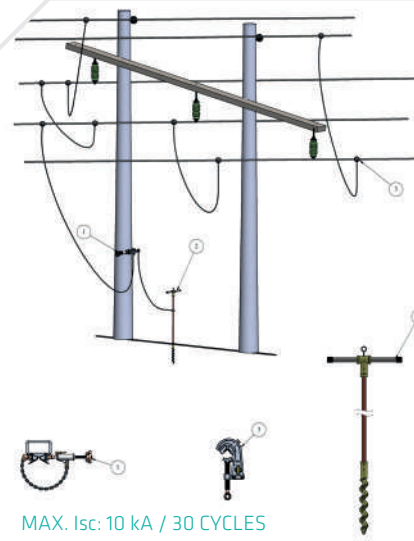

Temporary Grounding Equipment for Transmission Lines up to 138kV

SE28552-3

MAX. Isc: 10 kA / 30 CYCLES

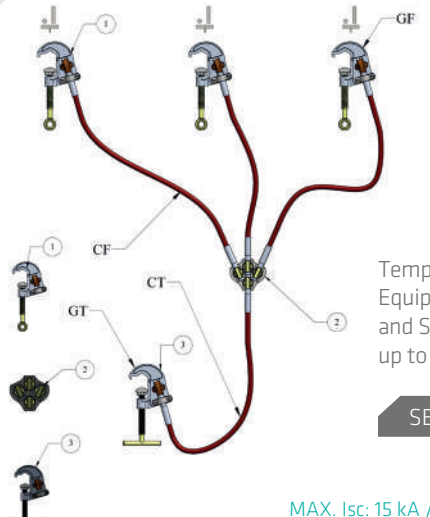

Temporary Grounding Equipment for Cubicles and Substations up to 36kV

SE23158-2

MAX. Isc: 15 kA / 30 CYCLES

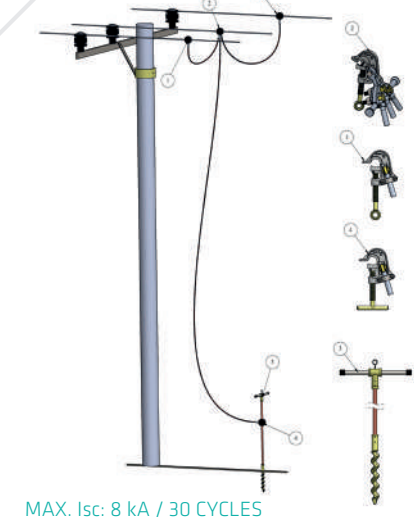

Temporary Grounding Equipment for high voltage Three-phase Networks up to 36kV

SE10845-2

MAX. Isc: 8 kA / 30 CYCLES

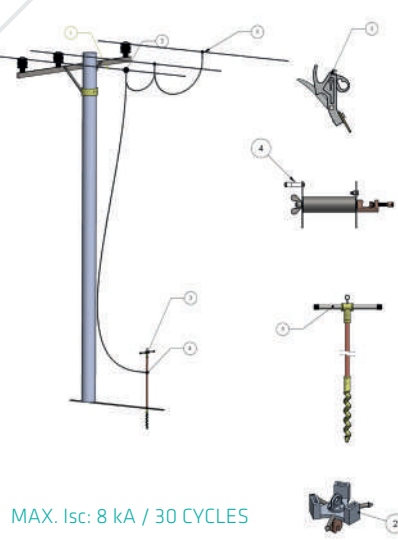

Temporary Grounding and Short-Circuiting Equipment for Distribution Networks up to 36kV

SE14765-2

MAX. Isc: 8 kA / 30 CYCLES

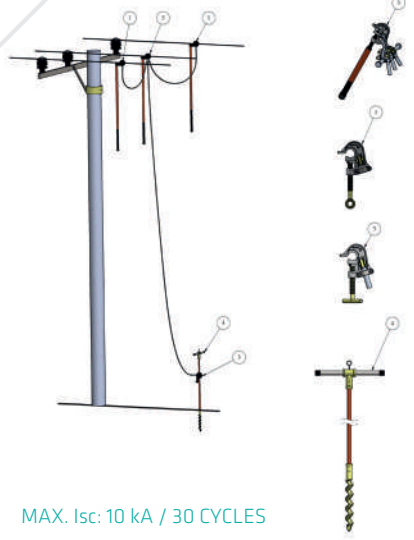

Temporary Grounding Equipment for high voltage Three-phase Networks up to 36kV

SE15742-2

MAX. Isc: 10 kA / 30 CYCLES

# GROUNDING CLAMPS AND GROUNDING ACCESSORIES

SE4514



GROUNDING CLAMP WITH EYE-BOLT FOR LV/MV SYSTEMS

SE4514T



GROUNDING CLAMP WITH T-BOLT

SE4733-2



BYPASS / GROUNDING CLAMP WITH EYE-BOLT

SE4733-2T



BYPASS / GROUNDING CLAMP WITH T-BOLT

SE711-1076



GROUNDING CLAMP WITH SERRATED JAW AND EYE-BOLT

SE711-1076T



GROUNDING CLAMP WITH SERRATED JAW AND T-BOLT

SE711-2854



GROUNDING / BYPASS CLAMP WITH EYE-BOLT

SE14764-2



GROUNDING CLAMP, ATTACHMENT BY SPRING ACTION

EY322NG



AUTOMATIC ATTACHMENT CLAMP FOR MEDIUM VOLTAGE SYSTEMS

# GROUNDING CLAMPS AND GROUNDING ACCESSORIES

SE5330-2



SE5339-21



SE21888-2



SE4470



GROUNDING CLAMPS FOR SUBSTATIONS

SE4478-4T



SE4478-3



SE4479



GROUNDING CLAMPS FOR SUBSTATIONS

SE22738-3T



SE22738-2



SE24158-3 / SE24158-2



NEUTRAL



PHASE

GROUNDING CLAMP FOR CUBICLE

GROUNDING CLAMP FOR CUBICLE WITH EYE-BOLT

PRESSURE-TYPE GROUNDING CLAMP WITH PROTECTIVE HANDLES

# GROUNDING CLAMPS AND GROUNDING ACCESSORIES

SE4474-2



ALUMINUM GROUNDING CLAMP

SE4474-5



GROUNDING CLAMP

SE711-1196



LARGE GROUNDING CLAMP

SE711-3342



GROUNDING CLAMP WITH SERRATED JAW

SE19058-2



GROUNDING CLAMP MOUNTED ON A FIBERGLASS POLE WITH NON-SLIP HANDLE

SE20544-2



DUCK-BILL GROUNDING CLAMP MOUNTED ON A FIBERGLASS POLE WITH NON-SLIP HANDLE

SE711-3432T

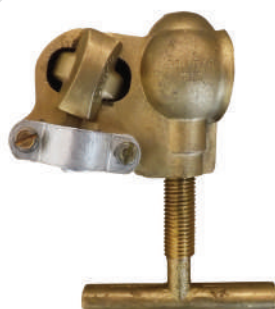

SOCKET CLAMP WITH T-BOLT

SE711-3411



SOCKET CLAMP WITH EYE-BOLT

SE19079-2



SOCKET CLAMP WITH EYE-BOLT

SE711-3431T



SOCKET CLAMP WITH T-BOLT AND THREADED CONNECTOR

SE24258-2



L-TYPE BALL-STUD CLAMP

SE19070-3



118MM STRAIGHT BALL-STUD CLAMP

# GROUNDING CLAMPS AND GROUNDING ACCESSORIES

SE21698-2



INSULATED COVER FOR BALL STUD CLAMPS

SE4002



BRASS DOUBLE-CONNECTOR FOR ONE EXTRA 5/8"-THREAD FERRULE

SE711-2695



JUMPER CONNECTOR

SE711-1972



GROUNDING CLAMP FOR FUSE SWITCH OPERATION WITH T-SUPPORT

SE711-3519



DISCONNECT HEAD FOR SWITCH OPERATION

SE711-1973



GROUNDING CLAMP FOR FUSE SWITCH OPERATION WITH L-SUPPORT

SE711-1952



L-TYPE CLAMP AND FUSE SUPPORT STUD

SE7601



THREADED PIN (M12, 1.75MM PITCH) FOR TEMPORARY GROUNDING - MECHANICAL STRENGTH 200 daN.

SE711-1902

Grounding Kit for static discharges in de-energizing equipment



ITEM	QTY.	UN.	PART N°	DESCRIPTION	WEIGHT (KG)
1	1	pc	-	33mm x 1.07m fiberglass pole	2,6
-	1	pc	SE4474-5	Grounding clamp with T-bolt	
-	-	m	SE25	25 mm <sup>2</sup> extra-flexible copper cable, with PVC clear-vision jacket.	

# GROUNDING CLAMPS AND GROUNDING ACCESSORIES

SE5865-2



4-WAY ALUMINUM TERMINAL BLOCK

SE15227-2



GROUNDING CLUSTER FOR MULTIPLE CLAMPS LIFTING

SE14752-2



STEEL REEL FOR TEMPORARY GROUNDING

SE15705-2



GROUNDING CLUSTER FOR LIFTING AND REMOVAL OF CLAMPS

SE-PEY4AP



GROUNDING CLUSTER FOR LIFTING UP TO 4 GROUNDING CLAMPS

SE-PEY3AP



GROUNDING CLUSTER FOR LIFTING UP TO 3 GROUNDING CLAMPS

SE11248-2



SE19925-2



GROUNDING RODS

SE14429-2



ALUMINUM SADDLE AND WHEEL TIGHTENER FOR TEMPORARY GROUNDING EQUIPMENT

SE17566-2



GALVANIZED STEEL PLATE SADDLE AND WHEEL TIGHTENER FOR TEMPORARY GROUNDING EQUIPMENT

SE14513-2



SE25588-2



ALUMINUM SADDLE AND NYLON STRAP FOR TEMPORARY GROUNDING EQUIPMENT

SE4736



ALUMINUM CLAMP-SUPPORT STUD

# MISCELLANEOUS

SE2369



FUSEHOLDER SUPPORT  
FITTING HEAD

SE5863



FUSEHOLDER SAFETY-TIE  
ASSEMBLY, MADE FROM STEEL

SE7718

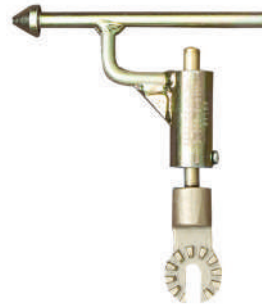

SWITCH OPERATION FITTING  
HEAD MADE FROM STEEL  
WITH FALL-PROTECTION SYSTEM

SE22665-2



OPERATION FITTING HEAD  
MADE FROM STEEL WITH  
FALL-PROTECTION SYSTEM

SE3696



ROUND AND "D&T" SHAPED POLE WRENCHES.  
RATED LOAD CAPACITY 2000KG.

SE2905



ROUND AND "D&T" SHAPED POLE WRENCHES.  
RATED LOAD CAPACITY 2000KG.

SE4482



REEL-RETRIEVING DEVICE.  
RATED LOAD CAPACITY 1500KG.

SE24018-2



POLE-PINS ASSEMBLY FOR  
KITE-THREADS REMOVAL.  
DIAM. 25MM X 30CM.

SE6973



RUBBER TRUCK-WHEEL CHOCK

SE3135



INSULATING RUBBER  
GLOVES INFLATOR

SE8134



UNIVERSAL HEAD FOR  
INSTALLATION OF LV AND  
MV SPACERS.

SE24016-2



UNIVERSAL FITTING HEAD  
WITH CUTTING BLADE.

# MISCELLANEOUS

SE5098

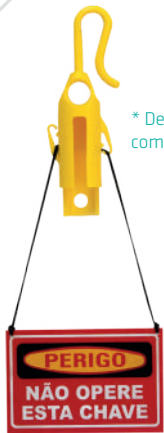

\* Device does not come with a plate.

TAGGING DEVICE FOR PLATES

SE5771



TOOL RACK

SE2053

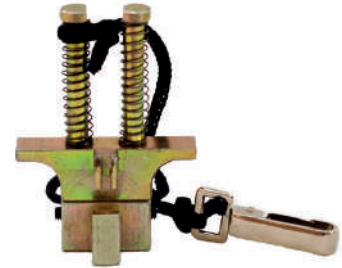

WEDGE CONNECTOR PULLER

SE7970

## FUNCTIONABILITY

Pole moving activities on distribution networks.

## GENERAL FEATURES

- Fiberglass pole handle;
- Ø32mm x 3.000mm long pole;
- Orange color;
- Mechanical strength 133daN;
- Provided with rope locking device;
- 6.0mm x 50mm 1020 steel bracket plate;
- Anticorrosive treatment;
- Red PVC coated jacket for rope protection;
- Ø16mm braided polyamide rope.

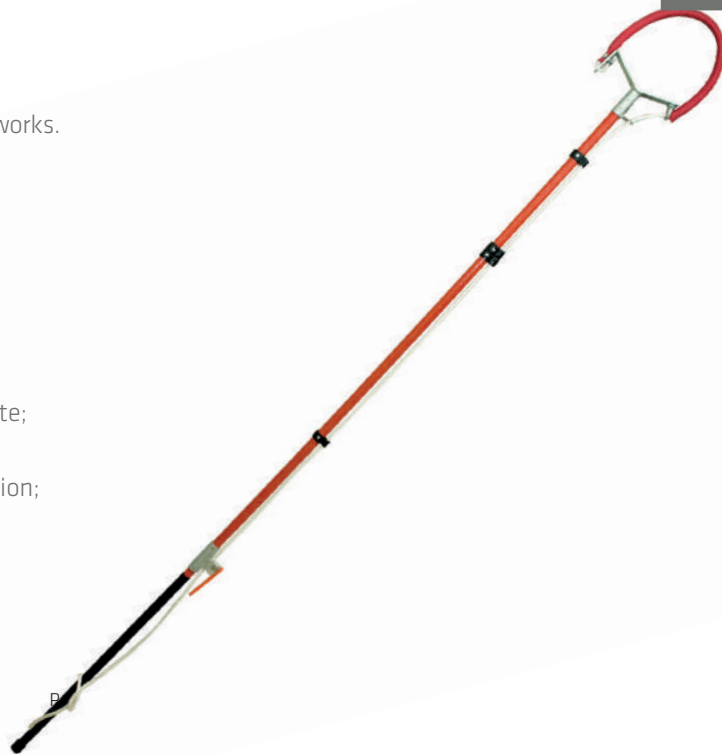

STICK FOR MOVING POLES

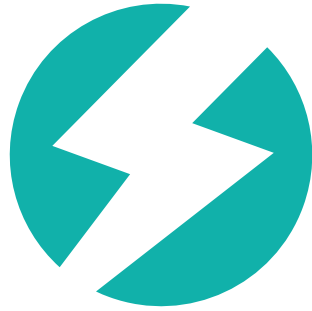

# SOLUÇÃO

EQUIPAMENTOS PARA REDES ELÉTRICAS

[www.sesolucao.com.br](http://www.sesolucao.com.br)



**POWERTRONICS PVT. LTD.**  
AN ISO 9001 : 2015 COMPANY

## **TAURUS POWERTRONICS PVT LIMITED**

**Corp. Off.:** No. 26, "Mahadimane", 12th Main, 1st Block, Rajajinagar, Bengaluru - 560 010. INDIA

**Sales & Service Off.:** No. 648/54, KLE College Road, 2nd Block, Rajajinagar, Bengaluru - 560 010

**Tel:** +91 7349644344, **Email:** [info@tauruspowertronics.com](mailto:info@tauruspowertronics.com), [enquiry@tauruspowertronics.com](mailto:enquiry@tauruspowertronics.com)

[www.tauruspowertronics.com](http://www.tauruspowertronics.com)

**BENGALURU**

**DELHI**

**KOLKATA**

**MUMBAI**

[www.tauruspowertronics.com](http://www.tauruspowertronics.com)