



### FEATURES

- The World First High Accurate AC/DC Leakage Current Testers.
- High Sensitive for Low Range Leakage Current.
- Suitable for Measurement of 4-20mA DC Controlled Circuit.
- DC mV Analog Signal Output.
- Lowest Influence from Magnetization & Terrestrial Magnetism.
- Wide Measuring Ranges - up to DC 1000mA & AC 10A.

### SPECIFICATIONS

Safety Standard	: IEC61010-1/61010-2-032 CATII 600V or CATIII 300V
Measuring function	: AC/DC current
Measuring method	: Clamp CT (CTP-05DC:Slide/Hook Type)
Jaw opening capability	: 5mmφ (CTP-05DC)
Measuring ranges	: DC 100mA/1000mA, AC 100mA/1000mA/10A (45Hz~65Hz)
AC current detection	: Average sensing
A/D conversion	: Dual integration method
Display	: Max. 2000 count on LCD with annunciator
Over range indication	: "OL" mark on LCD
Data hold indication	: "DH" mark on LCD
Zero adjustment	: For DC current range, by "0 ADJ" switch
Sampling rate	: 1 time/sec. for DC and 6 times/sec. for AC
Low battery indication	: "B" mark on LCD
Signal Output	: DC 100mV full scale to each range (output impedance: less than 10KΩ) Circuit voltage : less than AC/DC 500V
Operating temperature	: 0~50°C, < 85%RH (without condensation)
Storage temperature	: -10~60°C, < 70%RH (without condensation)
Withstanding voltage	: AC 3700V/1 minute between CT and outer case

Auto power off	: Approx. 10 minutes after power on and can absolve this function by switch
Power supply	: UM-4x4
Consumption Current	: Approx. 9mA (approx. 200h for continuous use)
Dimension	: Display Part 78(W)×155(H)×32(D)mm, approx. 280g, CT (CTP-05DC) 19(W)×133(H)×28(D)mm, approx. 100g
Accessories	: Soft Case, Batteries, Instruction Manual
Option	: Cable for Recorder

Accuracy  
Current (After zero adjustment by 0 ADJ switch)

Range	Measuring Range	Resolution	Accuracy
100mA	0.1~± 99.99mA	0.01mA	±1%rdg±10dgt
1000mA	1.0~± 300mA	0.1mA	±1%rdg±10dgt
	±300.1 ~± 700.0mA		±2%rdg±10dgt
	±700.1 ~± 999.9mA		±3%rdg±10dgt

- ※ Influence of Terrestrial Magnetism : Less than ±2.0mA
- ※ Influence of Magnetization : Less than ±2.0mA by DC 1.5A on/off
- ※ Influence of CT Open/Close : Less than ±1.0mA
- ※ Max Input Current : DC 1.5A (In case of over input more than DC 1.5A, output of CT will be lowered and the display will not become "OL")

### AC Current

Range	Measuring Range	Resolution	Accuracy
100mA	0~99.99mA	0.01mA	±2%rdg±10dgt (50/60Hz)
1000mA	0~999.9mA	0.1mA	±2%rdg±10dgt (50/60Hz)
10A	0~9.999A	0.001A	±1%rdg±10dgt (50/60Hz)

※ Max Input Current : AC 20A

## GROUND FAULT DC CURRENT MEASUREMENT IN PV SYSTEM BY MODEL 730

### 1. About DC Ground Fault Current in PV System

When the ground fault occurs at the DC current side of power conditioner, DC ground fault current will circulate from the earth to the DC current side of power conditioner via grounding line of boosting transformer & AC current side of power conditioner and then, through the inverter switching circuit. Consequently, DC ground fault current will be superposed to AC current and the current disparity will occur at P&N phase by the content of ground fault current.

### 2. About Detection of DC Ground Fault Current in Power Conditioner

ZCT built in DC current side of the internal power conditioner is monitoring current difference between P&N phase and power conditioner will stop, when the difference exceeds the limited value. Those limited values are different according to the power conditioner manufactures but they are generally 30mA~100mA.

### 3. About Measurement of DC Ground Fault Current by DC Current Clamp Tester

After making artificial ground fault (approx. 12mA), measurements of DC current at three places (grounding line of boosting transformer, DC current side of power conditioner and artificial ground fault point) were implemented by DC clamp tester (M-730). Consequently, the measured values of these three places were almost same, which means that all the DC ground fault current flowed out to AC current end and the current difference of P&N phase at DC current side of power conditioner was almost same as DC ground fault current.

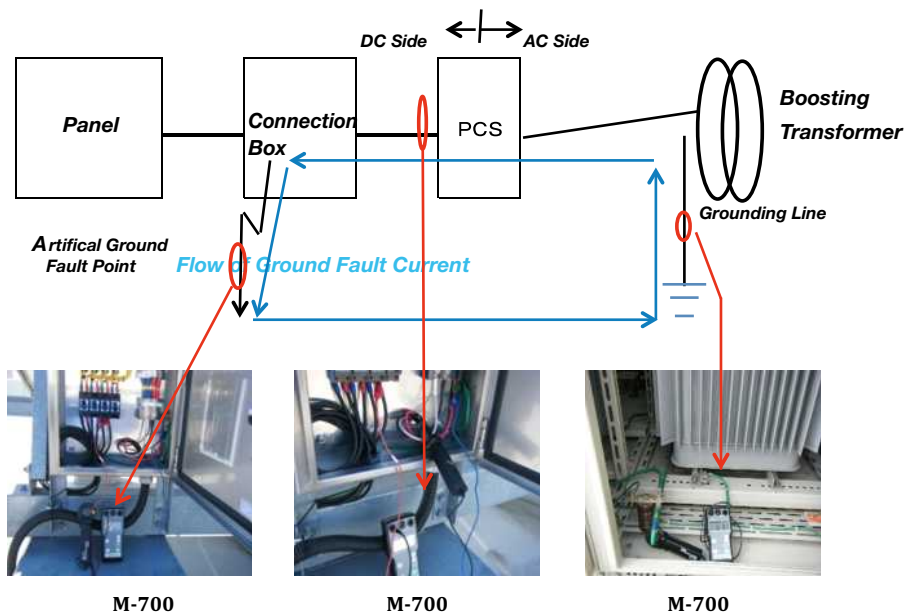

### 4. About Measurement of dark/sleeping current in automobiles

In a vehicle, a dark current draw continuously drains a small amount of current, usually a few milliamps, from a battery when the engine is off and the battery is not being continuously charged. Reducing the dark current draw on the battery increases the life of the battery as well as the length of idle time during which the battery will remain charged. The dark current leads to battery power loss caused problems, as well as the conventional power protection circuit device is directly turned off the vehicle, the car affect the normal use of a number of functional parts, provides an effective preventing battery power loss without affecting the automobile dark current intelligent control and protection system function of normal use.



## TAURUS POWERTRONICS PVT LIMITED

Corporate Off.: No. 26, "Mahadimane", 12th Main, 1st Block, Rajajinagar, Bengaluru - 560 010. INDIA, Tel : + 91 80 23012301  
Email : info@tauruspowertronics.com, care@tauruspowertronics.com, WhatsApp : +91 73496 44344  
Sales & Service Off.: No. 648/54, KLE College 2nd Block, Rajajinagar, Bengaluru - 560 010. INDIA.

BENGALURU  
DELHI  
KOLKATA  
MUMBAI